

TYPE OF PRODUCTS

Purifying UV-C lighting for cleanrooms, compact, recessed, IP65, access from the top, walkable. For sandwich false ceilings with cut-out. UV-C lamp 254 nm.

MECHANICAL CONSTRUCTION

The structure of the luminaire is made of 1 mm steel powder coated with KilBac white RAL 9003, certified qualicoat class 1 and antibacterial. Upper clamping frame made of 1.5mm lacquered steel. Top cover blue lacquered of 2 mm aluminium.

UV-C SOURCE

Philips low-pressure mercury vapour TUV-PL lamp with 254 nm wavelength emission. These sources contain a filter to avoid any ozone production.

OPTIC

- VRSI : quartz glass with special aluminium UV-C reflector.

CONTAMINATION CONTROL

Reduced risk of microbial growth :

>> KilBac technology, broad spectrum antibacterial finish with silver ions (BioCote, validated according to ISO 22196).

The mechanical construction of the luminaire ensures a particle emission class 3 according to ISO 14644-14. This range is made without silicone.

WALKABLE

Luminaires designed and tested to withstand the application of a 100 kg mass on the top cover corresponding to accidental feet pressure on the luminaire in the walkable plenum.

H₂O₂ RESISTANCE

The components that may come into contact with hydrogen peroxide during the decontamination process were tested by cyclic, direct and prolonged contact with a 35% H₂O₂ solution.

TEMPERATURE AND HUMIDITY

Reference ambient temperature : 20°C / 68°F. Operating temperature range : 5 to 25°C / 41 to 77°F (the temperature affects the lifetime of the LEDs). For environments with a moisture content of more than 70%, we recommend the use of lacquered INOX 304 for the housing, in option.

POWER SUPPLY

Luminaires supplied with European-branded EPF electronic no dimmable driver. Rated voltage 220-240 V.

INSTALLATION

Installation in sandwich panels from 15 to 100 mm. Adaptations for different thicknesses are possible on request. Quick installation without opening the luminaire.

WIRING

By a waterproof Wieland brand connector, RST20i, fixed to the top of the luminaire (installation on flexible cord).



DIMENSIONS (mm)

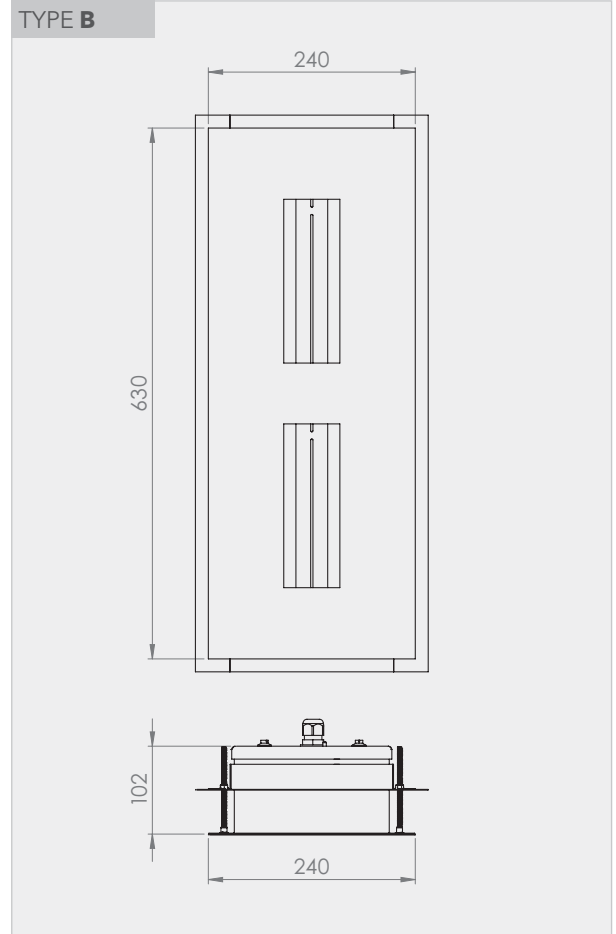
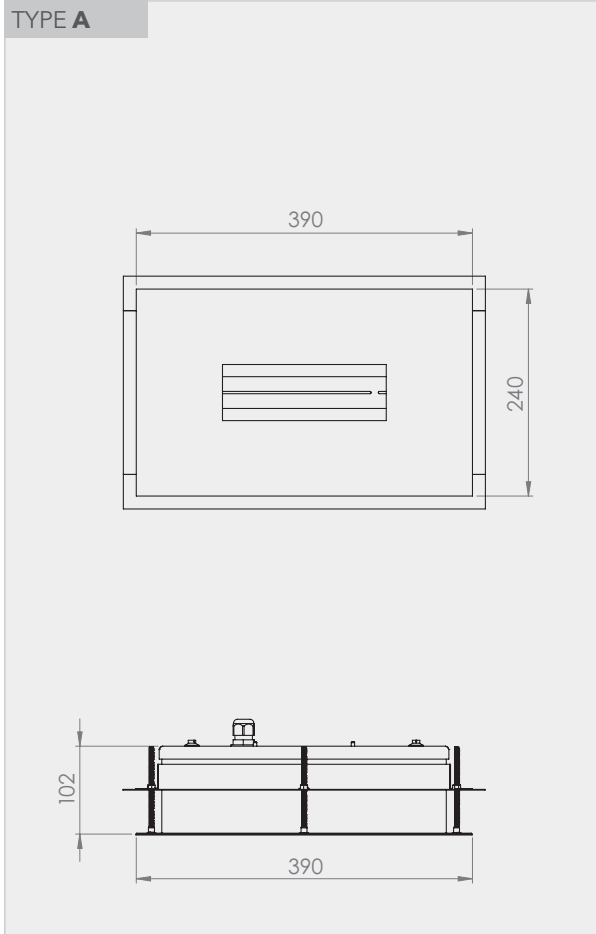

REFERENCES AND FEATURES

CODE	REFERENCE	Type	Cut-out (mm)	P (W)	UV power of the source (W)	Efficiency (%)	Weight (Kg)	H ₂ O ₂
VRSI optics - Quartz glass								
EUP2205EPF	Li3 VRSI 118 EPF	A	217x367	1x18	5,5	50	4,5	●
EUP2206EPF	Li3 VRSI 218 EPF	B	217x605	2x18	11	50	6	●
EUP2207EPF	Li3 VRSI 195 EPF	B	217x605	1x95	27	50	6	●

Light and power output tolerance ± 10%

UV-C AND SECURITY - NF EN ISO 15858:2016 NORME

DISINFECTION BY DIRECT RADIATION MUST ONLY BE DONE WHEN THERE IS NO UNPROTECTED HUMAN OR ANIMAL IN THE ROOM.

UV-C RADIATION

UVC radiation (100-280 nm) is invisible for humans, and exposure to UVC radiation can have health effects. Ocular damage usually begins with photokeratitis but can also result in photokeratoconjunctivitis. The symptoms, which may appear after several hours after exposure, can vary from a sudden sensation similar to that caused by sand in the eyes, to watery eyes and various levels of eye pain. Such symptoms may occur between 1 h and 12 h after exposure to UVC and resolve completely within 24-48 hours. Acute overexposure to UVC radiation can lead to disability due to ocular discomfort, but this will disappear after several days without permanent damage.

The skin lesions appear with an erythema, a redness of the skin similar to a sunburn, but without tanning. The most significant erythema occurs at a wavelength of 297 nm in the UVB band. UVC radiation at a wavelength of 254 nm does not cause such a significant erythema. This is one of the reasons why the areas subject to exposure should indicated and marked out. Warning signs should be placed at some locations to protect staff or visitors from the risks associated to UV. Appropriate locations include access doors, air handling units located outside walls, room doors, etc.

Allowable exposure time	Efficient irradiance $\mu\text{W}/\text{cm}^2$
24 h	0,07
18 h	0,09
12 h	0,14
10 h	0,17
8 h	0,2
4 h	0,4
2 h	0,8
1 h	1,7
30 min	3,3
15 min	6,7
10 min	10
5 min	20
1 min	100
30 s	200
15 s	400
5 s	1200
1 s	6000

note > This table is based on the NIOSH/ACGIH maximum exposure times for UV light from NIOSH/ACGIH

ISO 15858:2016(F)

MAXIMAL EXPOSURE ACCEPTABLE TO UV-C

This International Standard adopts the maximum allowable exposure values for UVC and the maximum exposure to UVC shall not exceed the ACGIH TLV and the NIOSH REL NIOSH REL of 6.0 mJ/cm² for an exposure of 8 h per day, 40 h per week to UV radiation at 254 nm.

The Threshold Limit Value® (TLV®) used should be based on the real occupation time of the spaces disinfected areas. This recommendation is supported by recent UV monitoring data from monitoring data from First and colleagues which indicate that the peak indicator give an unreliable prediction of the real exposure of room occupants.

ASSISTANCE TO PROJECTS AND IMPLEMENTATION

We offer technical assistance in the design of implementation projects. The simulation allows us to estimate the quantity of products to be installed but the real final results obtained need to be evaluated. In collaboration with certified laboratories, we can offer measurements of the radiation and its effects on site. These measurements allow us to validate the treatment the treatment process and, in particular, the right exposure time according to the objective.

Standards and warranty

Compliance : information on the compliance of our products with the relevant standards and directives is available on our website.

Warranty : our warranty conditions are indicated in our general terms and conditions of sale. There are special conditions depending on the product range. These conditions can be checked on our website : www.isoone-cleanroom-lighting.com/conditions-generales-de-vente/

Temperature and switches on : the operating temperature and the number of daily switches have an influence on the lifetime of the products. Our luminaires are designed to withstand at least 15.000 switches on following EU 1194/2012.

Please consult us for more information.

Note

ISOONE reserves the right to modify or update this document at any time within the framework of the technological evolution and the updating of our technical documentation. Despite the care taken in the design and the updating of this card, it can not under any circumstances constitute a contractual document.

UE Declaration of Conformity

LA MANUFACTURE DE FRANCE SAS
18 rue Jean Monnet
31240 Saint-Jean

CERTIFIES,
under its own responsibility, that the ISOONE luminaires **Li3**

EUP2205EPF EUP2207EPF
EUP2206EPF

are designed and manufactured in accordance with the following harmonized directives and standards :

SECURITY

2014/35/UE (26/02/2014)	Electrical equipment designed for use within certain voltage limits.
EN 60598-1 : 2015	Luminaires - Part 1 : General requirements and tests.
EN 60598-2-2 : 2012	Luminaires - Part 2-1 : Particular requirements - Fixed luminaires for general lighting.
EN 62493 : 2015	Assessment of lighting equipment related to human exposure to electromagnetic Field.
EN 62471 : 2008	Photobiological safety of lamps and devices using lamps.

ELECTROMAGNETIC COMPATIBILITY

2014/30/UE (26/02/2014)	European « EMC » Directive.
EN 55015 : 2013 + A1 : 2015	Limits and methods of measurement of electrical radio interference from electrical lighting and similar equipment.
EN 61000-3-2 : 2019	Electromagnetic compatibility (EMC) - Part 3-2 : Limits - Limits for harmonic current emissions (current drawn by equipment ≤ 16 A per phase).
EN 61000-3-3 : 2014	Electromagnetic compatibility (EMC) - Part 3-3 : Limits - Limitation of voltage changes, voltage fluctuations and flicker in public low-voltage supply systems, for equipment with rated current ≤ 16 A per phase and not subject to conditional connection.
EN 61547 : 2009	General purpose lighting equipment - EMC immunity requirements.

ECO-CONCEPTION

2009/125/CE (21/10/2009) + 2019/2020 (01/10/2019)
European « ErP » directive + regulation.

RESTRICTION OF DANGEROUS SUBSTANCES

2011/65/UE (08/06/2011) European directive « RoHS ».

Certificate issued on March 15th 2024

President, Frédéric Colombo